

TOLERANCE & MACHINE NOTES UNLESS OTHERWISE SPECIFIED		NAME	DATE
DIMENSIONS ARE IN INCHES @ 68-72 °		DRAWN	TM
TOLERANCES:		CHECKED	2/10/19
TWO PLACE DECIMAL	±0.010	ENG APPR	
THREE PLACE DECIMAL	±0.005	MFG APPR	
FOUR PLACE DECIMAL	±0.0005	COMMENTS	
MAXIMUM MACHINED SURFACE	0.004		
ANGULAR: ±0.10°			
CHAMFER ALL EDGES: 0.03 x 45°			
FILLET RADIUS: 0.015			
DO NOT SCALE DRAWING			

PTI Plasma Technics Inc.

TITLE: 79g Single Cell Reactor

SIZE: D DWG. NO: 79700-2 REV: 0

SCALE: 1:4 WEIGHT: SHEET 1 OF 2

REV.	CHANGES	DATE	ENG.
0	INITIAL RELEASE	2/10/2019	TM

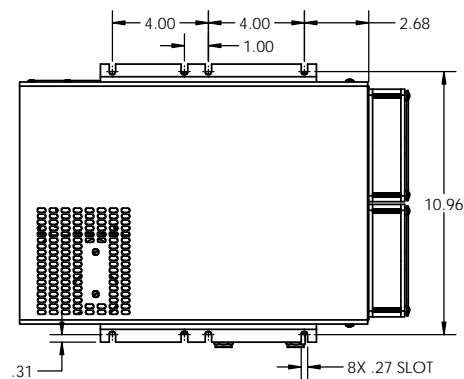
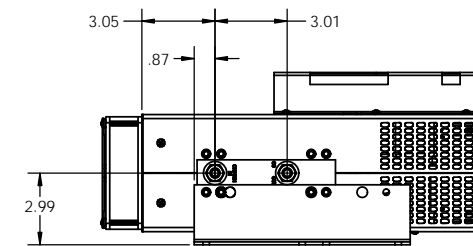
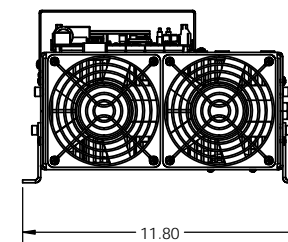
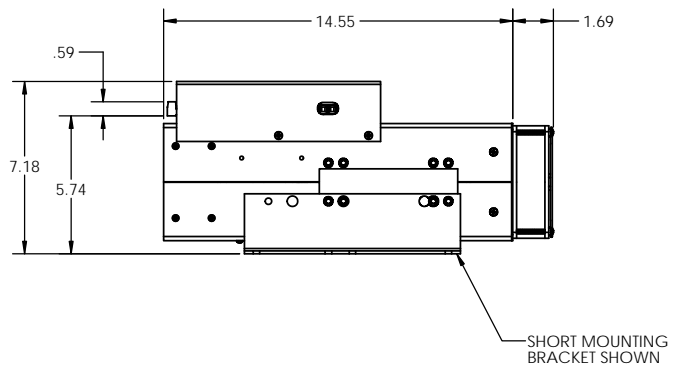
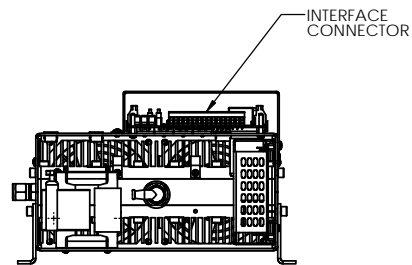
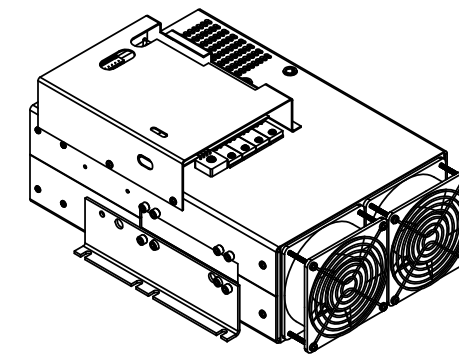
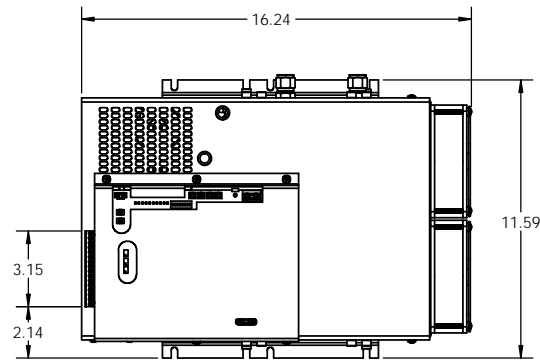
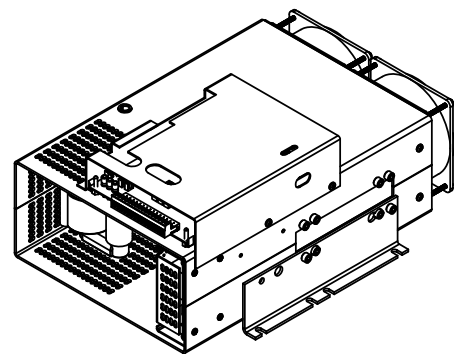

TOLERANCE & MACHINE NOTES UNLESS OTHERWISE SPECIFIED		NAME	DATE
DIMENSIONS ARE IN INCHES @ 68-72 °		DRAWN	TM
TOLERANCES:		CHECKED	2/10/19
TWO PLACE DECIMAL	±0.010	ENG APPR	
THREE PLACE DECIMAL	±0.005	MFG APPR	
FOUR PLACE DECIMAL	±0.0005	COMMENTS	
MAXIMUM MACHINED SURFACE	0.004		
ANGULAR: ±0.10°			
CHAMFER ALL EDGES: .03 x 45°			
FILLET RADIUS: .015			
MATERIAL			
HEAT TREATMENT			
FINISH			
DO NOT SCALE DRAWING			

PTI Plasma Technics Inc.

TITLE: 79700-2

SIZE: D DWG. NO: 79700-2 REV: 0

SCALE: 1:4 WEIGHT: SHEET 2 OF 2

REV.	CHANGES	DATE	ENG.
0	INITIAL RELEASE	2/10/2019	TM